

# MANISCOPIC

# MRT 3050 PRIVILEGE

- Lift height : 29.70 m
- Max. reach : 25.50 m
- Engine : 216 HP – 159 kW
- 4 wheel drive and steering
- Hydrostatic transmission with a powershift gearbox
- Suspended chassis



 **MANITOU**

**ROTATION ON STABILIZERS FULLY EXTENDED WITH FORKS 360°**

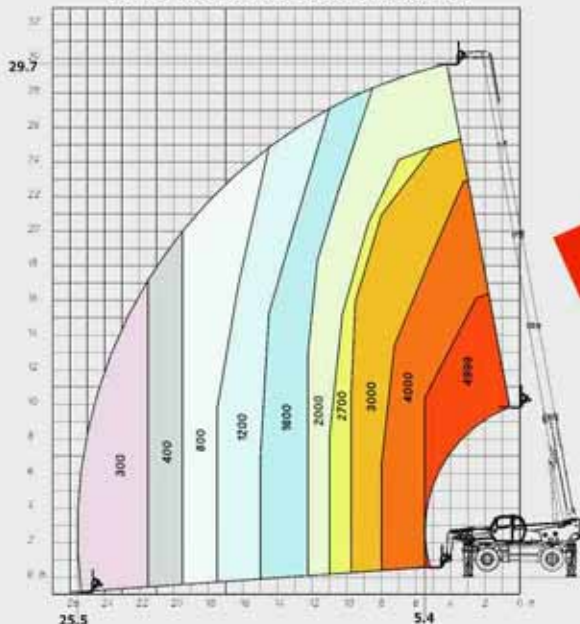

**HANDLING**

**FRONTAL POSITION ON WHEELS WITH FORKS**



**ROTATION ON STABILIZERS FULLY EXTENDED WITH 365 KG ORH PLATFORM - 2.25/4 M**

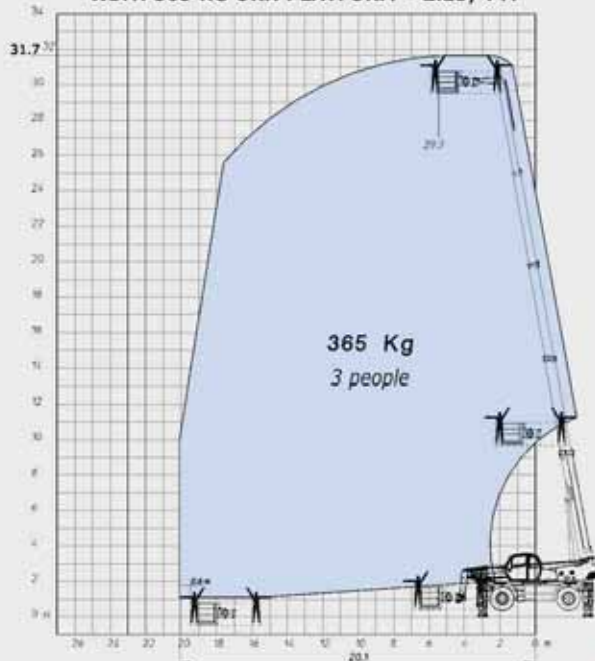

**ROTATION ON STABILIZERS FULLY EXTENDED WITH 1000 KG PLATFORM 2,25/4 M**

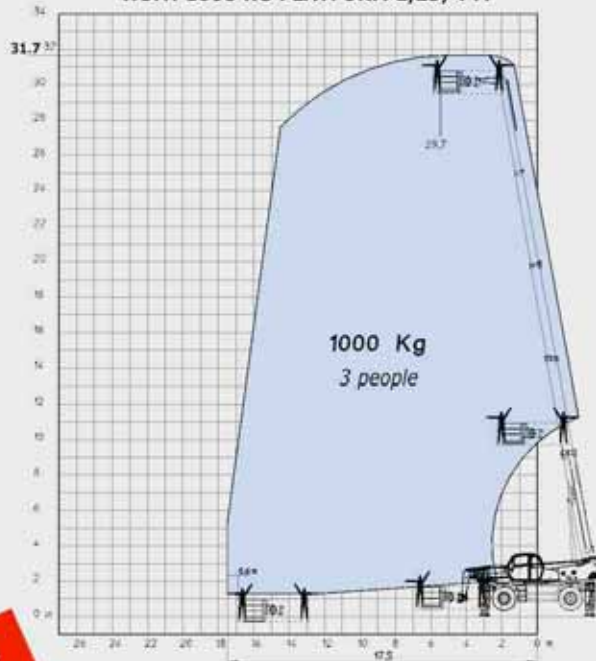

**ROTATION ON STABILIZERS FULLY EXTENDED WITH AERIAL JIB 1 PLATFORM**

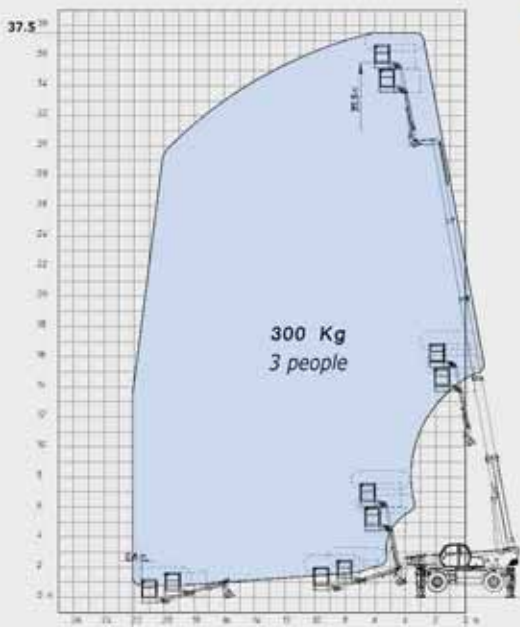

**PERSONNEL LIFT**

**ROTATION ON STABILIZERS FULLY EXTENDED WITH 3D SWING ARM IN POSITIVE POSITION**

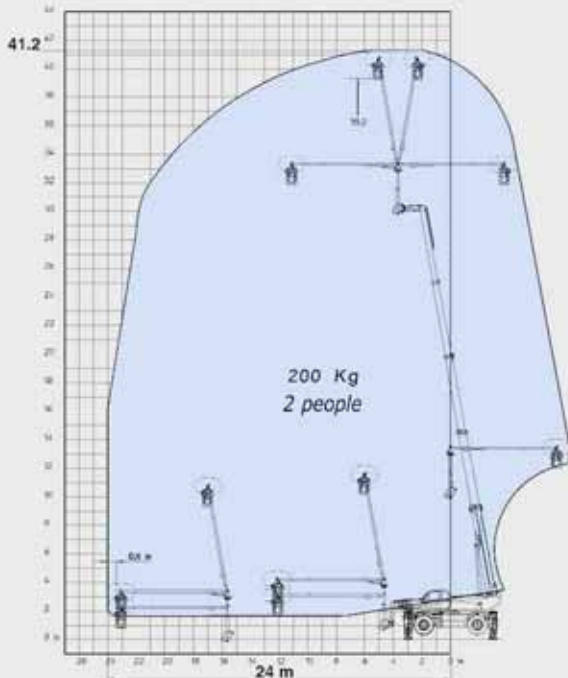

**POSSIBILITY TO WORK IN THE NEGATIVE POSITION**

**PRIVILEGE**

**MRT 3050**

**ROTATION ON STABILIZERS FULLY EXTENDED WITH TELESCOPE PT 800 JIB**

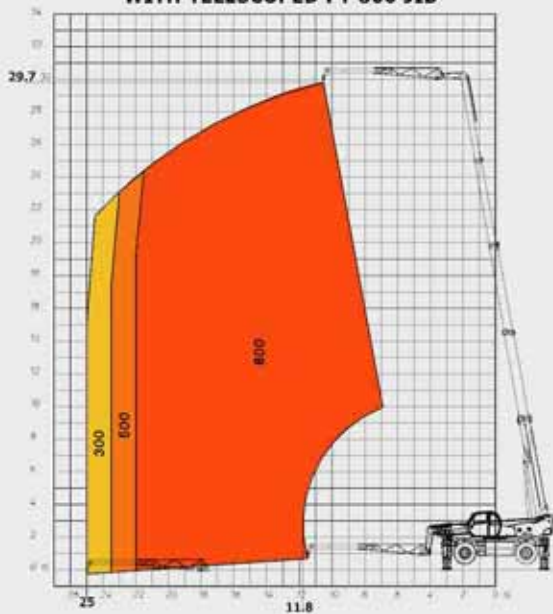

**ROTATION ON STABILIZERS FULLY EXTENDED WITH 1500 KG JIB**

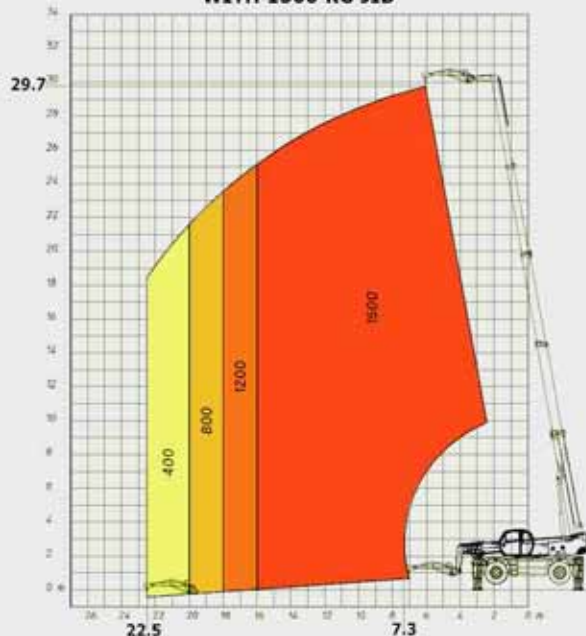

**ROTATION ON STABILIZERS FULLY EXTENDED WITH 3 T WINCH**

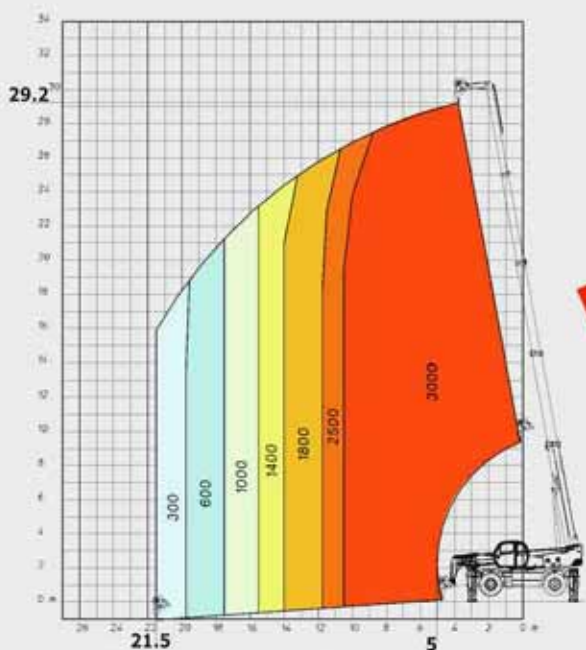

**LIFTING**

**ROTATION ON STABILIZERS FULLY EXTENDED WITH 5 T WINCH**

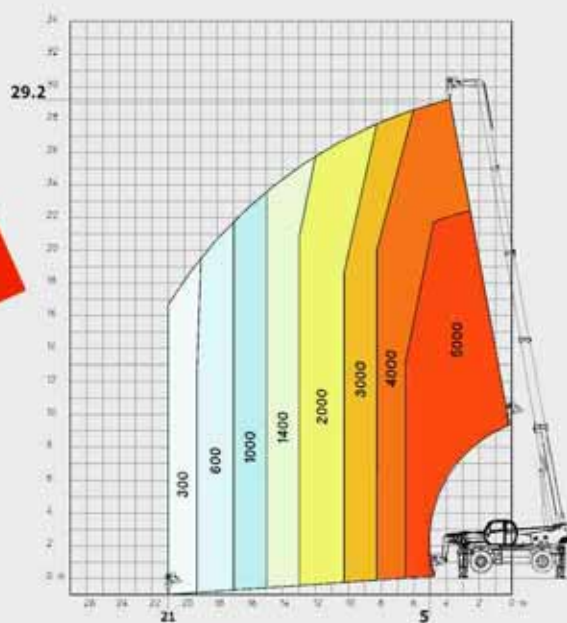

**ROTATION ON STABILIZERS FULLY EXTENDED WITH 12 T WINCH**

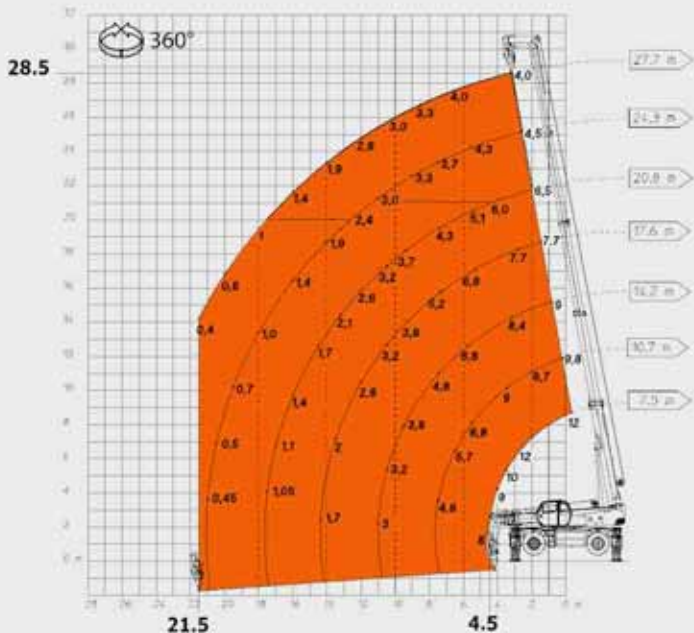

Lifting capacity	6 t	12 t
Sheaves	1	2
Lines	2	4
Rope diameter	14 mm	14 mm
Rope length	120 m	120 m
Max line pull	36.3 kN	36.3 kN
Available hook path at maximum boom extension	40 m	20 m
Available hook path at maximum boom retraction	50 m	25 m

# MRT 3050 *PRIVILEGE*

-  **Lift capacity** .....4999 kg  
at 500 mm from fork heels
-  **Lift height** (on stabilizers).....29.70 m
-  **Tyres**  
17.5 R 25
-  **Forks** (mm)  
Length.....1200  
Width x thickness.....150 X 50
-  **Oil-bath multidisc brakes** hydraulically assisted  
on both axles  
Negative parking brake
-  **PERKINS Engine**  
Type.....1106DE66TA - Euro3  
Capacity.....6 cyl. 6600 cm<sup>3</sup>  
Power (ISO/TR 14396) .....216 HP/159 kW  
932 Nm at 1400 rpm  
Water cooling  
Common-rail injection
-  **Power-regulated hydrostatic transmission**  
with a powershift gearbox  
(hydraulic variable-displacement pump  
and variable-capacity hydrostatic motor)  
Reversing shift .....electromagnetic  
Gearbox .....powershift  
Travel speed .....40 km/h\*  
\* this speed may be limited by local regulations
-  **Electronically controlled hydropneumatic suspension**  
**Lateral (8°) and longitudinal (3°)**  
Oscillating rear axle with automatic hydraulic lock  
when rotated (>15°)
-  **4 triplex telescopic stabilizers**  
simultaneously or individually controlled
-  **Total and continuous rotation**  
Turret mounted on a double slew ring  
Hydraulic swivel joint  
Electrical rotating connector
-  **Hydraulics**  
piston pump:  
variable displacement (Load Sensing)....270 bars/165 l/min  
gear pump.....220 bars/74 l/min
-  **Controls:** 2 electro-hydraulic proportional control  
joysticks for all hydraulic movements
-  **Capacities**  
Cooling system.....26 l.  
Engine oil.....15.5 l.  
Hydraulic oil .....285 l.  
Fuel tank .....310 l.
-  **Weight unladen** (with forks) .....22860 kg  
**Overall width**.....2.50 m  
**Overall height** .....3.26 m  
**Overall length** (without forks).....8.10 m  
**Ground clearance** .....0.42 m  
**Drawbar pull**.....10500 daN
-  **Standard load moment indicator**  
(mobile crane standards)

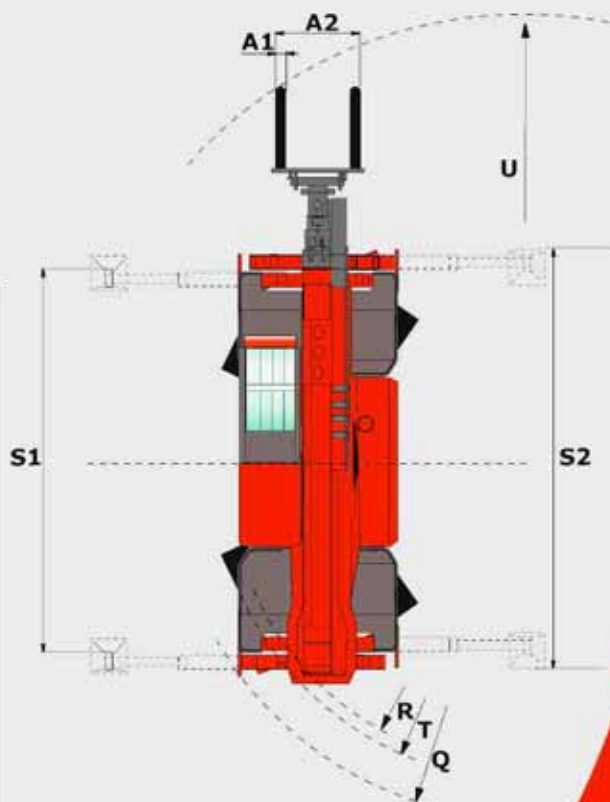
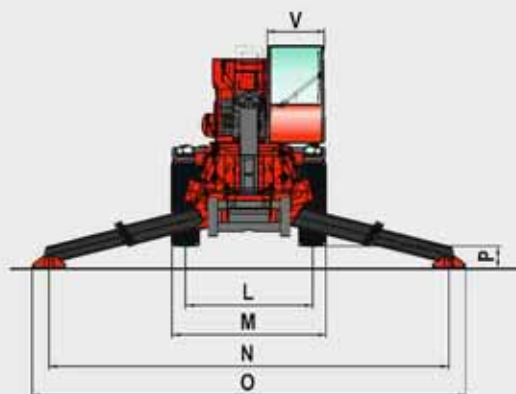
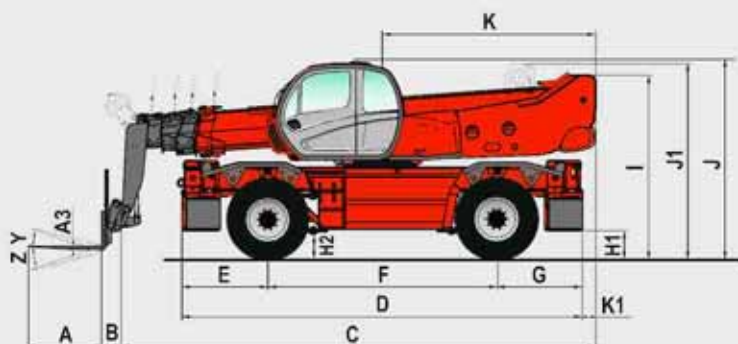

A	1200
A1	150
A2	1320
A3	50
B	320
C	7783
D	6787
E	1409
F	3750
G	1628
H1*	480
H2*	420
I*	3035
J*	3180
J1*	3160
K	3500
K1	218
L	2060
M	2498
N	6490
O	7100
P*	350
Q	5560
R	4690
S1	5945
S2	6490
T	4910
U	7000
V	923
Y	12°
Z	105°

mm  
\*Measured at suspension  
mid point ±78 mm



The specifications contained herein shall not bind the manufacturer and are subject to change without notice.  
The equipment described in this brochure can be standard, optional or unavailable, depending on the versions.  
For more details, contact your MANITOU dealer.

MANITOU BF SA

B.P. 249 - 44158 Ancenis Cedex - France  
Tel. : 33 2 40 09 10 11 / Export Department Fax : 33 2 40 09 10 97  
www.manitou.com

700381EN-D - 09/08

